

# Multi-functional wet ADIOX<sup>®</sup> scrubbers with integrated energy recovery



## The Måbjergværket Waste-to-Energy Plant at Holstebro, Denmark

*Götaverken Miljö has supplied two wet scrubbing plants for heat recovery and flue gas cleaning including dioxin removal to comply with authority requirements on dioxin emissions of below 0,1 ng TEQ/Nm<sup>3</sup>.*

*The contract included modification of existing scrubbers to “ADIOX<sup>®</sup> tower packing type” and provision of multi-stage tower packing scrubber systems.*

*The plant began full operation in 2004.*

**DONG**  
energy

**GÖTAVERKEN  
MILJÖ**

## General

The Måbjergværket municipal waste incineration plant was obliged to comply with the new EU waste directive. The modification was completed and the plant handed over to the client in December 2004. The upgrading of the old installation was made mainly to reduce emissions to following levels:

Dioxin	< 0,09	ng TEQ/Nm <sup>3</sup>
HCl	< 9	mg/Nm <sup>3</sup>
HF	< 0,9	mg/Nm <sup>3</sup>
SO <sub>2</sub>	< 45	mg/Nm <sup>3</sup>
Dust	< 9	mg/Nm <sup>3</sup>



Energy recovery by flue gas condensation is integrated into the flue gas cleaning system to generate additional revenue. The gas flow into the scrubber system is max. 2 x 105 000 Nm<sup>3</sup>/h.

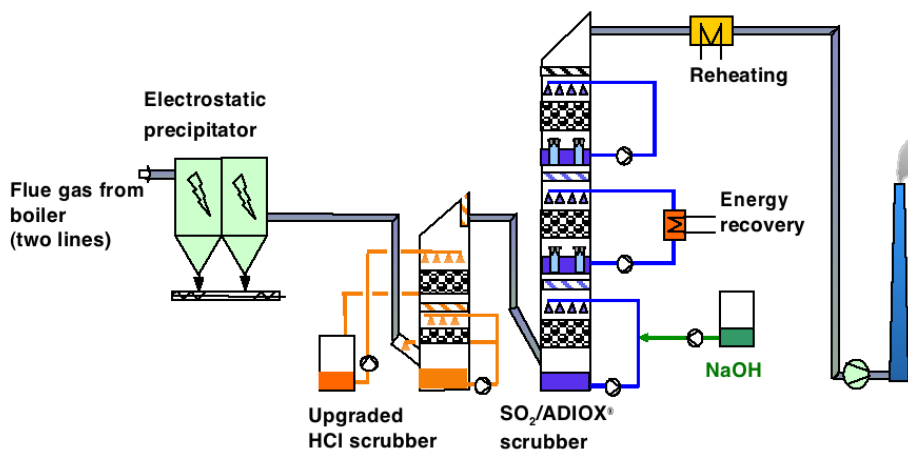

### Dioxin measurements

Raw gas (ng TEQ/Nm <sup>3</sup> )	Clean gas (ng TEQ/Nm <sup>3</sup> )	Removal efficiency
1,1	0,0038	99,70%
1,3	0,0025	99,80%
2,2	0,0048	99,80%
4,8	0,031	99,40%
1,6	0,0058	99,60%



## Description

Two incineration lines (2 x 9 tons/hour), were each originally equipped with an electrostatic precipitator and a two-stage "open type" acid (HCl) scrubber.

The contract included modification of existing scrubbers to "tower packing type" and provision of multistage tower packing scrubber systems. Also, exhaust fan systems and flue gas reheating were included.

The scrubber stages are all equipped with ADIOX<sup>®</sup> tower packing material for dioxin removal.

Modification of the existing scrubbers has improved the separation of not only hydrochloric acid (HCl) but also of other components such as mercury (Hg). NaOH is injected into the new multistage scrubber at the first stage to facilitate efficient SO<sub>2</sub>- separation. Most of the HF is also separated from the gas.

In the second stage, flue gases are cooled by a circulating cooling water system (indirect district heating water) enabling a substantial amount of energy to be recovered (nominal output 9 MW, maximum 14 MW).

For final dioxin removal an additional ADIOX<sup>®</sup> polishing stage is installed.

### Götaverken Miljö AB

Visiting address: Anders Carlssons gata 14  
 Postal address: Box 8876, SE-402 72 Göteborg, Sweden  
 Tel: +46-31-50 10 60, Telefax: +46-31-22 98 67  
[www.gmab.se](http://www.gmab.se)

