

# Extended energy recovery using flue gas condensation. ADIOX<sup>®</sup> as dioxin police filter

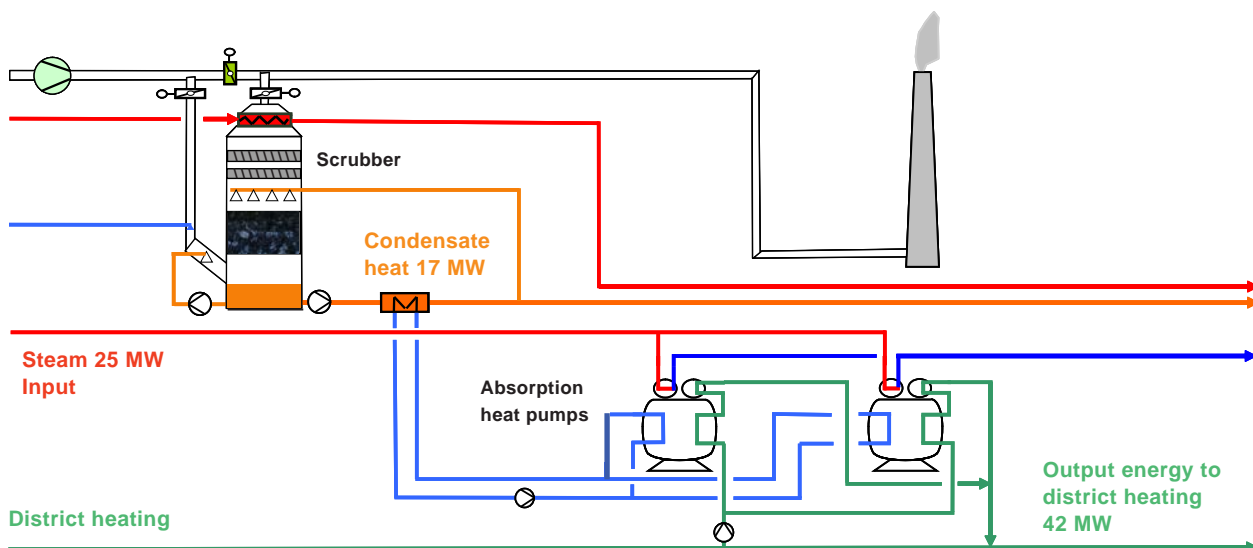

## The Vestforbrænding Waste-to-Energy plant in Copenhagen, Denmark

*Vestforbrænding is the largest waste-to-energy plant in Denmark. It produces 140.000 MWh of electricity and 440.000 MWh district heating. In February 2006, Götaverken Miljö was awarded the contract for the upgrading of line 5 including the installation of flue gas condensation and integrated absorption heat pumps.*



Energy mass balance, the transfer of energy from hot flue gases to the district heating system via a condensing scrubber and heat pumps..

## Description

The incineration line was operated using conventional wet scrubbing technology including a HCl and SO<sub>2</sub> scrubber. The plant has been expanded to allow a maximum of energy to be recovered from flue gases through the installation of a condensing scrubber and absorption heat pumps.



Condensing scrubber.

Flue gases are cooled by a circulating cooling water system, allowing a substantial amount of energy to be recovered (nominal output 13 MWth, maximum 17 MWth). The temperature of the heat recovered from the flue gases is lower than the district heating return temperature. Low value energy is raised to high value energy by two steam driven heat pumps in series and increasing the district heating temperature from 60°C to 80°C.

## ADIOX® as a police filter and dioxin memory effect prevention

Tower packings and droplet separators are made of ADIOX® material. In the event of an upstream failure of the flue gas treatment, ADIOX® will act as an additional police filter for dioxins. ADIOX® does not cause the memory effects that ordinary plastic material, used in scrubber internals, bring about.

## Design data:

- Waste throughput: 26 ton/h
- Thermal capacity: 74 MWth
- Flue gas flow: 150,000 Nm<sup>3</sup>/h (g.h.)
- Max extended energy recovery: 17 MW



Absorption heat pump.

GÖTAVERKEN MILJÖ AB

Visiting address: Anders Carlssons gata 14

Postal address: Box 8876, SE-402 72 Göteborg, Sweden

Tel: +46(0)31-50 19 60 Fax: +46(0)31-22 98 67

www.gmab.se

- a Babcock & Wilcox Vølund company

GÖTAVERKEN  
MILJÖ