

# Extended energy recovery using flue gas condensation with condensate treatment



## Sønderborg Waste-to-Energy plant, Denmark

*Sønderborg WTE plant identified a large potential to recover energy using flue gas condensation. In February 2007, Götaverken Miljö was awarded the contract for the upgrading of the plant by installation of a condensing scrubber. This was considered to be the best financial solution with respect to recovered energy versus investment costs.*

*Plant operation costs are also reduced due to lower fresh water consumption levels.*



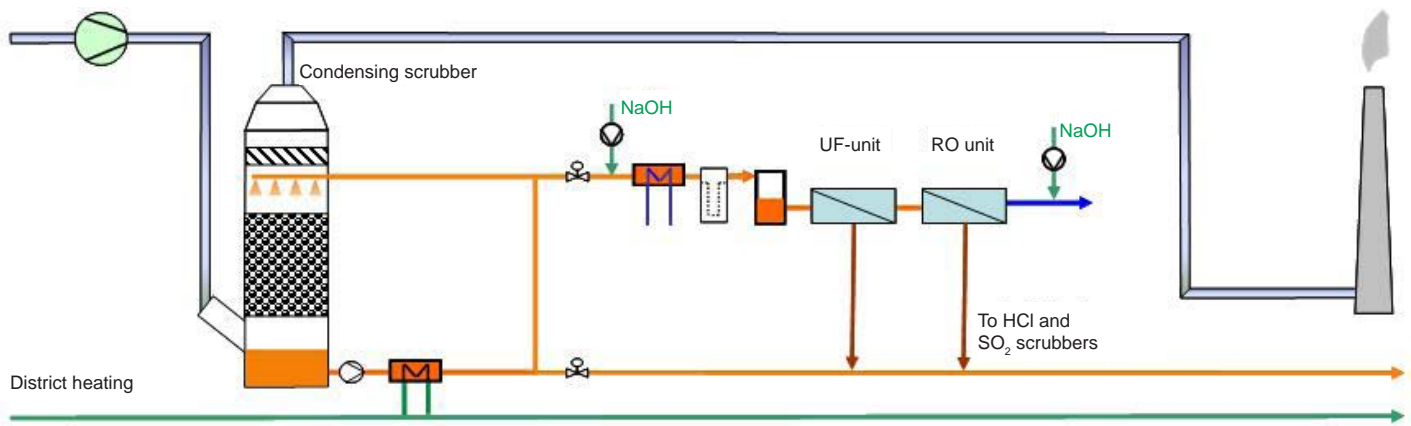

### Design data:

- Waste throughput 8 t/h
- Flue gas flow 58.000 Nm<sup>3</sup>/h (w.g.)
- Max energy recovery 6 MW

### Description

The incineration line uses conventional wet scrubbing technology with a HCl and a SO<sub>2</sub> dioxin scrubber. The plant has been upgraded with a condensing scrubber and condensate treatment.

Flue gases are cooled by a circulating cooling water system (indirect district heating water) which allows a substantial amount of energy to be recovered (nominal output 4.5 MWth).

Scrubber during installation.



The condensate water produced is fed back upstream to the flue gas cleaning scrubbers. In normal operation, this water replaces all the fresh water used in the gas treatment.

At maximum load, more water will be condensed than the upstream scrubber system consume. Surplus water is therefore be cleaned in the condensate treatment, consisting primarily of ultra filtration (UF) and reverse osmosis (RO) units.

The UF removes suspended solids and larger organic molecules. The RO removes salts and metallic ions by using semi-permeable membranes. The concentrate from the RO/UF system is fed back to the scrubber process and the permeate goes to recipient. However, there is a potential to reuse this hot water as make up water for the boiler, after additional deionization. This also generates savings via lower fresh water consumption and lower levels of energy consumption.

### ADIOX<sup>®</sup> as police filter and dioxin memory effect prevention

Droplet separators and tower packings are made of ADIOX<sup>®</sup> material. In the event of an upstream failure of flue gas treatment, ADIOX<sup>®</sup> will act as a police filter for dioxins. Memory effect problems (desorption of dioxins in plastics) are avoided by using ADIOX<sup>®</sup>.

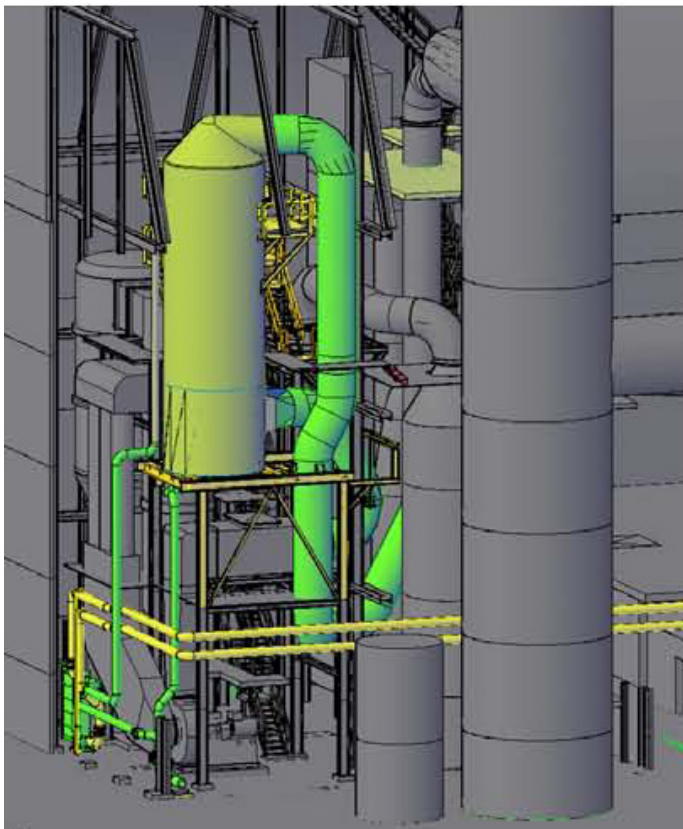

GÖTAVERKEN MILJÖ AB

Visiting address: Anders Carlssons gata 14

Postal address: Box 8876, SE-402 72 Göteborg, Sweden

Tel: +46(0)31-50 19 60 Fax: +46(0)31-22 98 67

[www.gmab.se](http://www.gmab.se)

- a Babcock & Wilcox Vølund company

